

EN

OPERATING MANUAL  
LAYER THICKNESS  
MEASURING DEVICE



**Table of contents**

Notes regarding the operating manual..... 2

Safety ..... 2

Information about the device..... 3

Transport and storage..... 5

Operation ..... 5

Menu structure ..... 10

PC software..... 11

Errors and faults..... 11

Maintenance and repair ..... 11

Disposal ..... 12

**Notes regarding the operating manual**

**Symbols**



**Warning of electrical voltage**

This symbol indicates dangers to the life and health of persons due to electrical voltage.



**Warning**

This signal word indicates a hazard with an average risk level which, if not avoided, can result in serious injury or death.



**Caution**

This signal word indicates a hazard with a low risk level which, if not avoided, can result in minor or moderate injury.

**Note**

This signal word indicates important information (e.g. material damage), but does not indicate hazards.



**Info**

Information marked with this symbol helps you to carry out your tasks quickly and safely.



**Follow the manual**

Information marked with this symbol indicates that the operating manual must be observed.

You can download the current version of the operating manual and the EU declaration of conformity via the following link:



BB20



<https://hub.trotec.com/?id=43284>

**Safety**

**Read this manual carefully before starting or using the device. Always store the manual in the immediate vicinity of the device or its site of use!**



**Warning**

**Read all safety warnings and all instructions.**

Failure to follow the warnings and instructions may result in electric shock, fire and / or serious injury.

**Save all warnings and instructions for future reference.**

This appliance can be used by children aged from 8 years and above and persons with reduced physical, sensory or mental capabilities or lack of experience and knowledge if they have been given supervision or instruction concerning use of the appliance in a safe way and understand the hazards involved.

Children shall not play with the appliance. Cleaning and user maintenance shall not be made by children without supervision.

- Do not use the device in potentially explosive rooms.
- Do not use the device in aggressive atmosphere.
- Protect the device from permanent direct sunlight.
- Do not remove any safety signs, stickers or labels from the device. Keep all safety signs, stickers and labels in legible condition.
- Do not open the device.
- Observe the storage and operating conditions as given in the Technical data chapter.

**Intended use**

Only use the device for coating thickness measurements. Observe and comply with the technical data.

To use the device for its intended use, only use accessories and spare parts which have been approved by Trotec.

## Improper use

Do not use the device in potentially explosive atmospheres, for measurements in liquids or at live parts. Trotec accepts no liability for damages resulting from improper use. In such a case, any warranty claims will be voided. Any unauthorised modifications, alterations or structural changes to the device are forbidden.

## Personnel qualifications

People who use this device must:

- have read and understood the operating manual, especially the Safety chapter.

## Residual risks



### Warning

Risk of suffocation!

Do not leave the packaging lying around. Children may use it as a dangerous toy.



### Warning

The device is not a toy and does not belong in the hands of children.



### Warning

Dangers can occur at the device when it is used by untrained people in an unprofessional or improper way! Observe the personnel qualifications!



### Caution

Keep a sufficient distance from heat sources.

### Note

To prevent damages to the device, do not expose it to extreme temperatures, extreme humidity or moisture.

### Note

Do not use abrasive cleaners or solvents to clean the device.

## Information about the device

### Device description

The device BB20 is used to determine the coating thickness on ferromagnetic and non-ferromagnetic metal surfaces. The measuring device functions according to the magnetic induction principle (for coatings on ferromagnetic surfaces) or the turbulent flow principle (for coatings on non-ferromagnetic surfaces).

The BB20 is a compact and versatile device suitable for quick, precise and non-destructive measurements of coating thicknesses.

### Device depiction

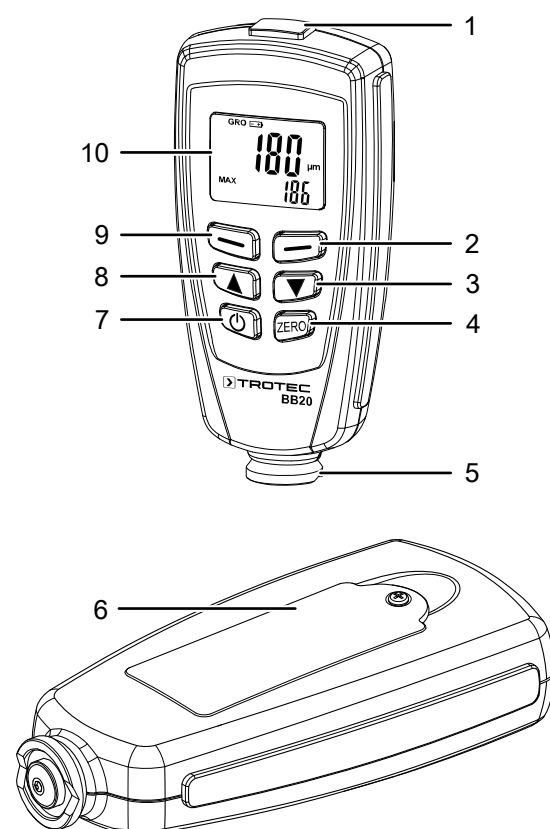

No.	Designation
1	USB interface
2	Blue button (back / cancel)
3	▼ button
4	ZERO button
5	Sensor
6	Battery compartment with cover
7	Power button
8	▲ button
9	Red button (select / confirm)
10	Display

**Display**

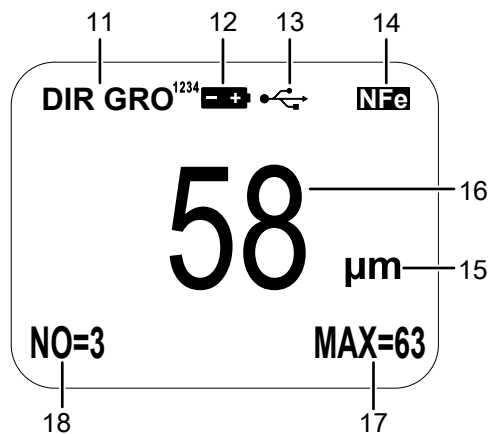

No.	Designation
11	Working mode display
12	Battery indication
13	PC access display
14	NFe/Fe display
15	Indication of the unit
16	Layer thickness display
17	Statistical data display: AVG, MAX, MIN, SDEV
18	Number of measured values

**Technical data**

Parameter	Value	
Model	BB20	
Sensor	<b>F</b>	<b>N</b>
Functional principle	Magnetic induction	Turbulent flow
Measuring range	0 to 1250 μm 0 to 49.21 mils	0 to 1250 μm 0 to 49.21 mils
Guaranteed tolerance (of the measured value)	0 to 850 μm (±3 % ±1 μm) 850 to 1250 μm (±5 %) 0 to 33.46 mils (±3 % ±0.039 mils) 33.46 to 49.21 mils (±5 %)	0 to 1000 μm (±3 % ±1.5 μm) 850 to 1250 μm (±5 %) 0 to 33.46 mils (±3 % ±0.059 mils) 33.46 to 78.7 mils (±5 %)

Parameter	Value	
Accuracy	0 to 50 μm (0.1 μm) 50 to 850 μm (1 μm) 850 to 1250 μm (0.01 mm) 0 to 1.968 mils (0.001 mils) 1.968 to 33.46 mils (0.01 mils) 33.46 to 49.21 mils (0.1 mils)	0 to 50 μm (0.1 μm) 50 to 850 μm (1 μm) 850 to 1250 μm (0.01 mm) 0 to 1.968 mils (0.001 mils) 1.968 to 33.46 mils (0.01 mils) 33.46 to 49.21 mils (0.1 mils)
Minimum bending radius	1.5 mm	3 mm
Diameter of the smallest measuring surface	7 mm	5 mm
Critical primary layer thickness	0.5 μm	0.3 μm
Ambient temperature	0 to 40 °C (32 to 104 °F) at 20 to 90 % RH	
Power supply	2 batteries 1.5 V AAA	
Dimensions (length x width x height)	114 x 27 x 54 mm	
Weight	152 g	

**Scope of delivery**

- 1 x Layer thickness measuring device BB20
- 2 x 1.5 V batteries AAA
- 1 x Transport case
- 1 x Steel and aluminium base plate with different film thicknesses for calibration
- 1 x USB cable
- 1 x Operating manual
- 1 x PC software

## Transport and storage

### Note

If you store or transport the device improperly, the device may be damaged.

Note the information regarding transport and storage of the device.

### Transport

For transporting the device, use the transport case included in the scope of delivery in order to protect the device from external influences.

### Storage

When the device is not being used, observe the following storage conditions:

- dry and protected from frost and heat
- protected from dust and direct sunlight
- For storing the device, use the transport case included in the scope of delivery in order to protect the device from external influences.
- The storage temperature is the same as the range given in the Technical data chapter.
- Remove the batteries from the device.

## Operation

### Inserting the batteries

- Insert the supplied batteries before first use.

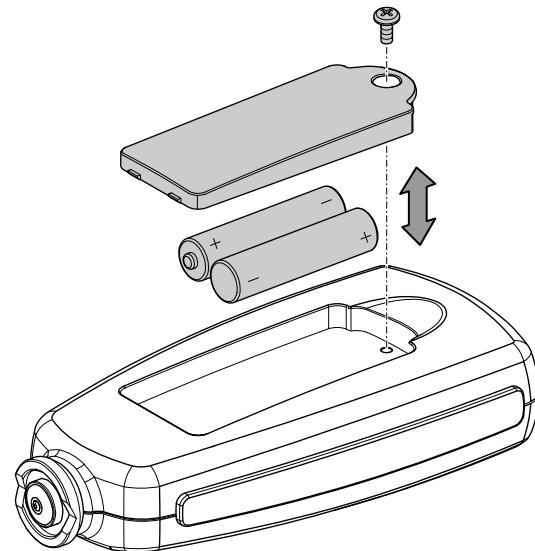

1. Loosen the screw and open the battery compartment (6).
2. Insert the new batteries in the battery compartment (6) with correct polarity.
3. Place the cover back on the battery compartment (6) and reinsert the screw.

### Switching the device on



#### Info

Note that moving from a cold area to a warm area can lead to condensation forming on the device's circuit board. This physical and unavoidable effect can falsify the measurement. In this case, the display shows either no measured values or they are incorrect. Wait a few minutes until the device has become adjusted to the changed conditions before carrying out a measurement.

1. Press the Power button (7).  
⇒ The display will be switched on and the device ready for operation.

### Menu

Press the Red button (9) to open the main menu.

Press the ▼ (3) or ▲ button (8) to select the desired menu item.

In order to confirm the selected menu item, press the Red button (9) again.

Press the Blue button (2) to return to the previous menu item.

### Setting the measuring mode

To adjust the measuring mode, please proceed as follows:

1. Press the Red button (9) to open the main menu.
2. In the menu, select the menu item *Options* and confirm by pressing the Red (9) button.
3. Select the *Measure mode* menu item, then, select the desired mode. Confirm with the Red button (9).

#### Single mode:

After every measurement, an acoustic signal will be emitted. All measurements are automatically saved.

#### Continuous mode:

The sensor must not be lifted between the individual measurements. No acoustic signal will be emitted after the measurement. All measurements are automatically saved.

### Setting the working mode

To set the working mode, please proceed as follows:

1. Press the Red button (9) to open the main menu.
2. In the menu, select the menu item *Options* and confirm by pressing the Red (9) button.
3. Select the *Working mode* menu item, then, select the desired mode. Confirm with the Red button (9).

The device offers two different working modes:

#### DIRECT:

This mode is suitable for quick and easy measurements. Measurements are cached during a measurement series.

Once the device is switched off or changes into another working mode, the measurement results will be deleted. The statistical analysis programme is able to assess 80 measurements. Once the memory is full, the oldest measurements will be overwritten.

#### GROUP:

The GROUP mode comprises group 1 to 4. In each group, 80 individual and 5 statistical measurements can be saved.

Calibration and limit values can be adjusted and saved individually.

Once the memory is full, current measurements will no longer be saved. Measurements can be carried out as usual.

### Setting the sensor mode

To adjust the sensor mode, please proceed as follows:

1. Press the Red button (9) to open the main menu.
2. In the menu, select the menu item *Options* and confirm by pressing the Red (9) button.
3. Select the *Used probe* menu item, then, select the desired mode. Confirm with the Red button (9).

- **AUTO:**

The sensor automatically selects a measuring mode.

- **Fe:**

The sensor operates according to the magnetic induction principle if it is placed on a magnetic surface.

- **Not Fe:**

The sensor operates according to the turbulent flow principle if it is placed on non-magnetic metals.

### Units

You can choose between metric ( $\mu\text{m}$  and  $\text{mm}$ ) and imperial ( $\text{mils}$ ) units.

If the measured value exceeds 850  $\mu\text{m}$ , the device switches to  $\text{mm}$ .

To change the unit, proceed as follows:

1. Press the Red button (9) to open the main menu.
2. In the menu, select the menu item *Options* and confirm by pressing the Red (9) button.
3. Select the *Unit setting* menu item, then, select the desired unit. Confirm with the Red button (9).

### Reset

Resetting deletes the entire data in all memories. In order to carry out a reset, follow these steps:

1. Switch the device off.
2. Simultaneously press the Zero button (4) and the Power button (7).  
⇒ *sure to reset* will be displayed.
3. Press the Red button (9) to confirm or the Blue button (2) to cancel the process.

The device automatically switches back on.

### Background illumination

In the menu, you can control the background illumination using *Options* and *Backlight*, during a measurement, use the Blue button (2).

### Indication of statistics

In the menu item *LCD Statistic*, you can choose between the following indications:

- Average
- Maximum
- Minimum
- Standard deviation (*Sdev.*)

The selected indication appears in the bottom right corner of the display in the statistical data indication (17).

Statistics of the measured values appear on the bottom left corner in the display in the measured values indication (18).

To view all statistical values of the respective groups, go to the menu and select *Statistic view*.

### Measured value indication

To view all measured values of the respective groups, go to the menu and select *Measure view*.

### Automatic switch-off

The device switches off after 3 minutes of inactivity. To deactivate automatic switch-off, go to the *Options* section in the menu and select the *Auto poweroff* function. Select *Disable* and confirm by pressing the Red (9) button.

### Device calibration

Carry out a calibration before each measuring operation.

You can perform the calibration e.g. at an untreated or uncoated spot of the object to be tested or use the set included in the scope of delivery.

### Calibration mode

1. Press the Red button (9) to open the main menu.
2. Select the *Calibration* menu item, then select *Enable*.  
⇒ You return automatically back to *Calibration*.
3. Press the Blue button (2) to return back to the start screen. Calibration is carried out here.  
⇒ The following messages appear on the display:
  - cal zero: There is **no** one-point or two-point calibration.
  - cal 1 to 2: There is a one-point or two-point calibration.
  - zero y: There is a zero-point calibration.



#### Info

Please bear in mind that the device at hand is a precision measuring device that can determine coating thicknesses of no more than a few micrometres (1  $\mu\text{m}$  is equivalent to one thousandth of a millimetre).

The surface condition of most measuring objects is hardly ever perfectly even and homogeneous, even though it might appear differently to the naked eye. Observed under the microscope, even the smoothest surface looks much like a mountain and valley landscape. The tiniest of scratches, cavities or contaminations can therefore already have a negative effect on the expected measurement result, seeing as they will also be a part of the measurement to a greater or lesser extent. It does, however, not affect the accuracy of the device. Even after the calibration unexpected measurement deviations of a few micrometres always have to be regarded in this context.

Hence it is important to handle the supplied calibration accessories with care to avoid scratches and dirt on their respective surface as far as possible.

**Zero point calibration**

- ✓ An uncoated sample is required.
- 1. Place the sensor onto an **uncoated** sample. The calibration sample is to be identical with the actual sample in terms of material composition, shape and surface condition.
- ⇒ The following message will be displayed:



- 2. Lift the sensor again and keep it away from the sample (at least 10 cm).
  - 3. Press and hold the Zero button (4) for approx. 2 seconds.
  - ⇒ The following result appears on the display:
- <0.0 μm>  
CAL1  
ZeroY
- ⇒ The calibration is terminated.

**One-point calibration**

This calibration is suited for high-precision measurements, e.g. for thin coatings.

- ✓ A calibration film, a coated and an uncoated sample are required.
- 1. Activate the calibration mode as described before.
- 2. Carry out a zero-point calibration.
- 3. Place the calibration film on an **uncoated** sample.
- 4. Place the sensor on the sample.
- ⇒ The measurement is effected.
- 5. Lift the sensor again.
- 6. Adjust the required film thickness by using the Down/Right (3) or the Up/Left (8) button. The film thickness should be at least the size of the estimated coating thickness.
- 7. Repeat this step several times.
- 8. Now carry out the measurement on a coated sample.
- 9. Press the Zero button (4) to adopt the current calibration.
- 10. To exit the current calibration, press the Blue button (2).

**Two-point calibration**

This calibration is especially suited for measurements on rough surfaces or for high-precision measurements.

- ✓ You need two films of different film thickness. The thicker film should be approx. 1.5 times thicker than the thinner film.
- 1. At first, carry out a zero-point calibration.
- 2. Using the first film, carry out a one-point calibration.
- 3. Repeat this step with the second film.
- 4. Place the sensor onto the coating that is to be measured. After a brief acoustic signal is emitted, you can lift the sensor again.
- ⇒ The measured value appears on the display.

**Calibration on radiated surfaces**

Values of layer thickness measurements carried out on radiated surfaces are usually too high. The average thickness can be determined as follows:

**Method A**

- 1. Carry out the steps for one-point and two-point calibration as described above. Use a smooth sample with the same surface curvature and material type as the measuring object that is to be used later on.
  - 2. In order to determine the average value  $X_0$ , carry out approx. 10 measurements on the uncoated sample.
  - 3. Afterwards, carry out approx. 10 measurements on the coated sample to determine the average value  $X_m$ .
  - ⇒ The difference between both average values is the average coating thickness  $X_{eff}$ . Take the standard deviation of both values  $X_m$  and  $X_0$  into account.
- $$X_{eff} = (X_m - X_0) \pm S$$

**Method B**

- 1. Carry out a zero calibration with approx. 10 measurements on an uncoated sample.
- 2. Afterwards, carry out a film calibration on the uncoated sample.
- 3. Repeat this calibration with films of different thicknesses (max. thickness 50 μm). Together, these films should be as thick as the assumed layer thickness.
- ⇒ The layer thickness can be read from the display.

**Method C**

- 1. Carry out the steps for two-point calibration with two films as described above.
- 2. Use several 50 μm films to approach the actual surface as precisely as possible.
- ⇒ The layer thickness can be read from the display.



## General information on measurements

If the calibration has been carried out correctly, the measured value lies within the guaranteed measuring tolerance. Incorrect measured values can be deleted in the menu. The last value results from the statistical calculation and the guaranteed degrees of tolerance of the measured value.

Strong electrical or electromagnetic fields can influence the measured values.

The measuring tip is to be cleared of contamination prior to each calibration.

Wait for at least 4 seconds after each measurement before proceeding to the next measurement as the device does not respond to measurement sequences carried out too quickly.

## Deleting functions

In order to delete measured values, select *Delete* in the menu, then select the measured values you would like to delete.

- **Current Data**  
Deletes the last measured value.
- **All Data**  
All data can be deleted during the respective working mode.
- **Group Data**  
Comprises *Delete all data*. In addition, the limit values and one-point and two-point calibration values will be deleted.

## Limit value functions

Limit values can be entered using the *Limit* function. It is possible to enter limit values before, during or after carrying out measurement series.

1. Press the Red button (9) to open the main menu.
2. Select the *Limit* menu item, then select *Limit setting*.  
⇒ Using the ▼ (3) and ▲ (8) buttons, you can determine the upper limit value in the *High limit* section and the lower limit value in the *Low limit* section.

Each measured value beyond the fixed tolerance limit appears on the display as follows:

**H:** Measured value is above upper limit value.

**L:** Measured value is below lower limit value.

## Statistical measurements

The device is able to calculate statistics based on 80 measurements. A total of 400 measured values can be saved.

No measured values are saved in direct mode, however, calculating statistics is possible.

If you change between the different working modes or if the device is switched off, statistics are deleted from the direct mode.

The following statistical values are calculated:

- **NO.:** Number of measured values in working mode
- **AVG:** Average
- **Sdev.:** Standard deviation
- **MAX:** Maximum value
- **MIN:** Minimum value

## Memory space full

If the memory space is full in group mode, statistics will no longer be updated. However, measurements can still be carried out. These measurements will not be part of the statistics.

In single measurement mode, *FULL* appears on the display.

If the memory space is full in direct mode, old measurements are replaced by new ones and statistics will be updated.

## Menu structure

Main menu	Submenu 1	Submenu 2
Statistic view ( <i>Statistic view</i> )	Average view Minimum view Maximum view Number view Standard deviation view ( <i>Sdev. view</i> )	-
Options	Measuring mode	Single mode Continuous mode
	Working mode ( <i>Working mode</i> )	Direct Group 1 Group 2 Group 3 Group 4
	Used probe ( <i>Used probe</i> )	AUTO Fe Not Fe
	Units ( <i>Unit setting</i> )	µm mils mm
	Background illumination ( <i>Back-light</i> )	On Off
	LCD Statistic <i>LCD Statistic</i>	Average Maximum Minimum Standard deviation
	Automatic switch-off ( <i>Auto poweroff</i> )	Activate Deactivate
Limit values ( <i>Limit</i> )	Limit value settings ( <i>Limit settings</i> )	Upper limit value Lower limit value
	Delete limit value ( <i>Delete limit</i> )	-

Main menu	Submenu 1	Submenu 2
Delete	Current data	-
	All data	
	Group data	
Measured value indication ( <i>Measure view</i> )	-	-
Calibration	Activate ( <i>Enable</i> )	-
	Deactivate ( <i>Disable</i> )	
	Delete zero N	
	Delete zero F	

## PC software

Using the software *Coating Thickness Tester* stored measurement data can be called up and saved via USB cable.

The software is available for download at [www.trotec.de](http://www.trotec.de).



### Info

The supplied free software is designed for useful basic functionalities. Trotec assumes no liability with regard to this free software and also provides no support on that score. Trotec accepts no liability concerning the use of this free software and is under no obligation to make adjustments or to further develop updates or upgrades.

### Installation requirements

Ensure that the following minimum requirements for installing the PC software are fulfilled:

- Supported operating systems:
  - Windows 7
  - Windows 8
  - Windows 8.1
  - Windows 10
- Hardware requirements:
  - Standard USB interface
  - Min. 7 MB of free hard disk space
  - Recommended resolution: 1280\*1024 with 16 bit
  - .NET Framework 2.0 or higher

### Installing the PC software

1. Insert the data medium with the software into the drive or download the current software from the *Service* area of Trotec download centre.
2. Double-click the installation file *Setup.exe*.
3. Follow the instructions of the installation wizard.

### Starting the PC software

1. Connect the device to the PC using the supplied USB cable.
2. Start the PC software.
  - ⇒ The software connects to the device.
  - ⇒ Data stored on the device can now simply be visualised in form of a chart or graphic.

### Saving measured values (export)

You can export a selected group as csv or txt file and save it on your PC. There the table looks as it does in the software.

1. Open the desired file.
2. You select either *Save \*.TXT* or *Save \*.CSV*.

## Errors and faults

The device has been checked for proper functioning several times during production. If malfunctions occur nonetheless, check the device according to the following list.

### The device does not switch on:

- Check the charging status of the batteries. Change the batteries, if required.
- Check that the batteries are properly positioned. Check the polarity is correct.
- Never carry out an electrical check yourself; instead, contact your Trotec customer service.

### Table of faults

The following error codes can be displayed:

Error code	Cause of error
Err1, Err2, Err3	Faulty contact between sensor and mainboard
Err1	Faulty signal of eddy-current sensor
Err2	Faulty signal of magnetic induction sensor
Err3	Faulty signals of both sensors
Err4, Err5, Err6	No meaning, reserved for later versions of the device
Err7	Faulty measurement. There might be a hardware problem.

## Maintenance and repair

### Battery change

A battery change is required, when the battery indication (12) lights up or the device can no longer be switched on. See chapter Operation

### Cleaning

Clean the device with a soft, damp and lint-free cloth. Make sure that no moisture enters the housing. Do not use any sprays, solvents, alcohol-based cleaning agents or abrasive cleaners, but only clean water to moisten the cloth.

### Repair

Do not modify the device or install any spare parts. For repairs or device testing, contact the manufacturer.

## Disposal



The icon with the crossed-out waste bin on waste electrical or electronic equipment stipulates that this equipment must not be disposed of with the household waste at the end of its life. You will find collection points for free return of waste electrical and electronic equipment in your vicinity. The addresses can be obtained from your municipality or local administration. For further return options provided by us please refer to our website <https://de.trotec.com/shop/>.

The separate collection of waste electrical and electronic equipment aims to enable the re-use, recycling and other forms of recovery of waste equipment as well as to prevent negative effects for the environment and human health caused by the disposal of hazardous substances potentially contained in the equipment.



In the European Union, batteries and accumulators must not be treated as domestic waste, but must be disposed of professionally in accordance with Directive 2006/66/EC of the European Parliament and of the Council of 6 September 2006 on batteries and accumulators. Please dispose of batteries and accumulators according to the relevant legal requirements.

Trotec GmbH

Grebener Str. 7  
D-52525 Heinsberg

☎ +49 2452 962-400

☎ +49 2452 962-200

✉ [info@trotec.com](mailto:info@trotec.com)

[www.trotec.com](http://www.trotec.com)